

HS Series Coaxial Array Speakers



DESCRIPTION

One of the most difficult speaker requirements to satisfy is a cost-effective mid-size speaker system that offers high quality sound no matter what the application. TOA HS Series speakers are equipped with $90^\circ \times 40^\circ$ directivity control. This useful feature allows tailoring the speaker's dispersion characteristics to better suit the acoustic environment in which it is installed. The versatile HS-1200/1500 Series are compatible for use with 100V/70V lines for distributed applications. The HS Series speakers are exceptional in offering useful features at an attractive price.

FEATURES

Large diameter woofer (12"/15") in a compact, lightweight enclosure

With its compact dimensions and light weight, the HS Series proves ideal for use in mid to small-size venues, including restaurants and pubs, conference rooms and lecture halls, schools and similar locations, as well as for temporary installations.

Uniform high quality sound is made possible by mounting the high frequency driver array in a coaxial configuration with the woofer.

- Extended bass frequencies for rich music reproduction
- Optimal sound delivery with well integrated low and high frequencies

Optimal choice for acoustical problems caused by high ceilings that tend to reduce the clarity of sound reproduction, such as in sports facilities, multi-purpose halls and houses of worship.

Coaxial Tweeter Array delivers accurate directivity control
HS Series speakers are equipped with $90^\circ \times 40^\circ$ directivity control. Well-balanced sound is delivered without treble attenuation to where the speaker is aimed, filling the acoustic space with clear sound.

Versatile installation

Unobtrusive design makes an ideal choice for permanent installations.

Optional dedicated mounting brackets facilitates speaker installs on walls and ceilings.

Accessory handle for easy transportability

Secure floor setting

- Accessory rubber feet for straight positioning.
- Wedge-shape enclosure enables use as a floor monitor.

Lineup:

12"/15" woofer, black and white finishes, low-impedance and high/low-impedance models are available.

Twin input terminal sets

The speakon terminal is ideal for quick temporary installation and for testing purposes. The screw terminals are recommended for long-term installation.

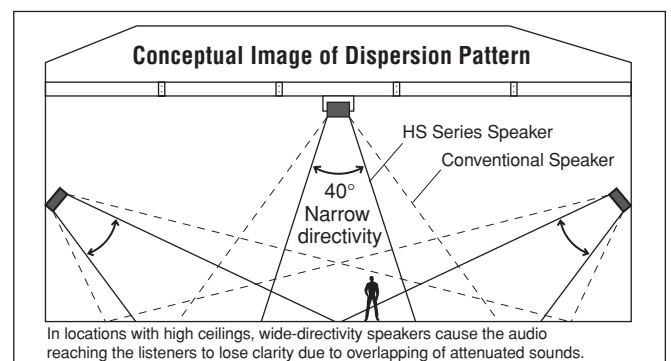

Polar Response (Horizontal)

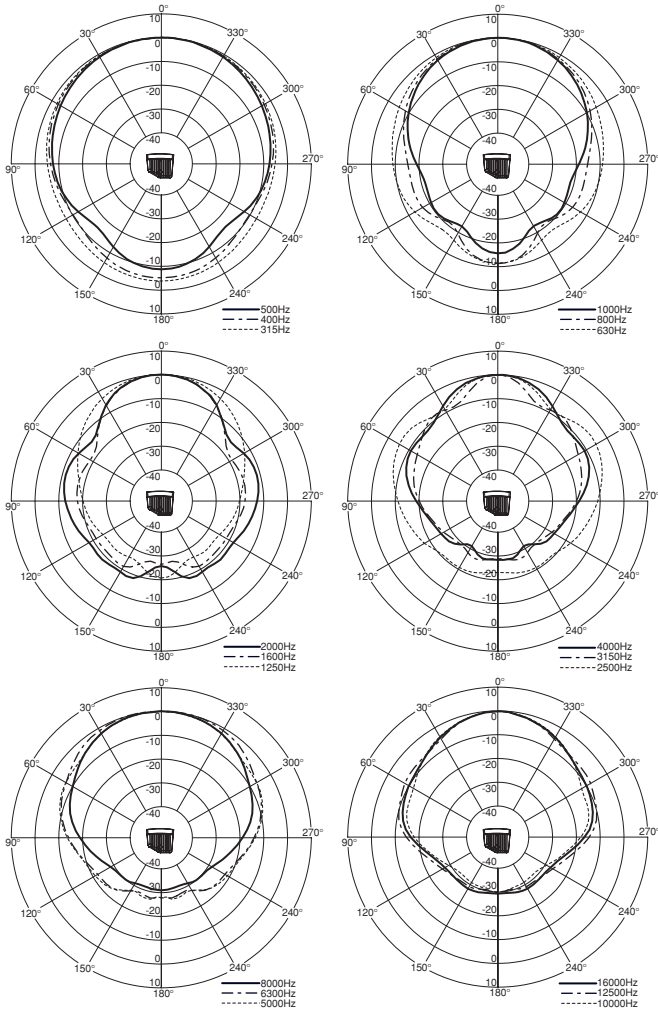

Polar Response (Vertical)

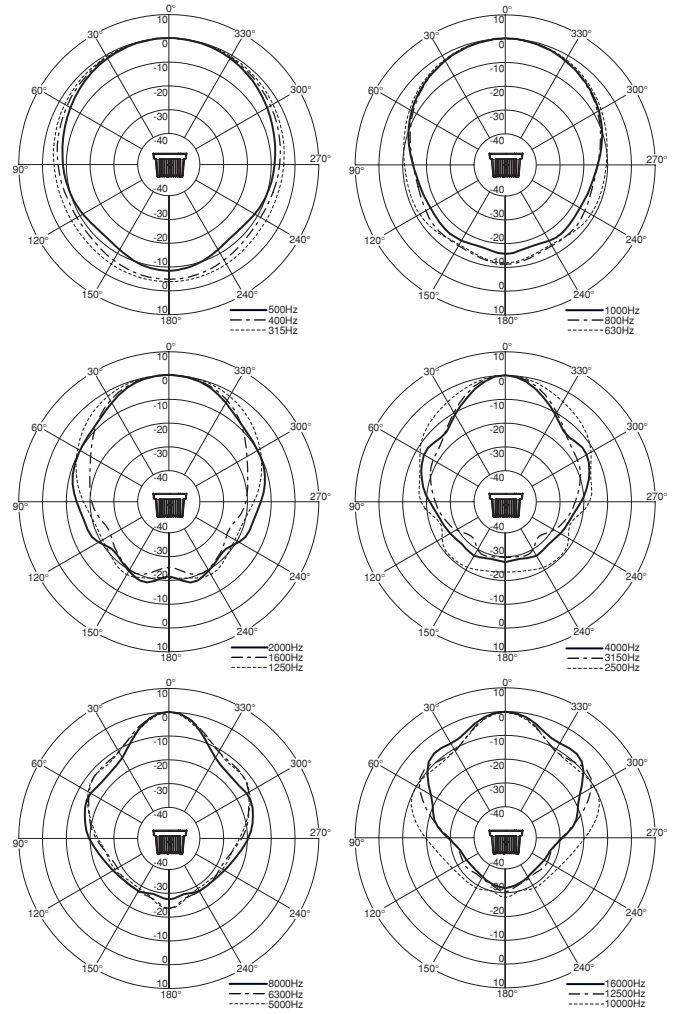

SPL vs. Frequency

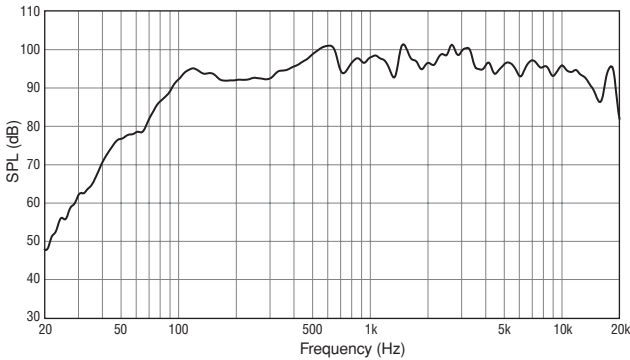

Impedance vs. Frequency

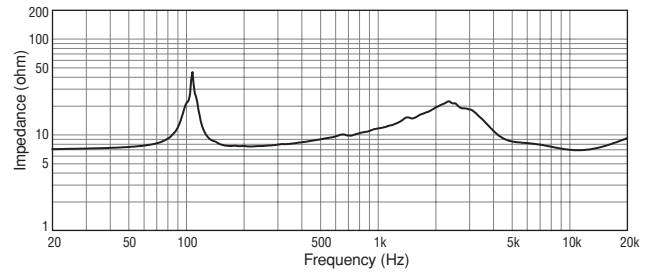

Phase vs. Frequency

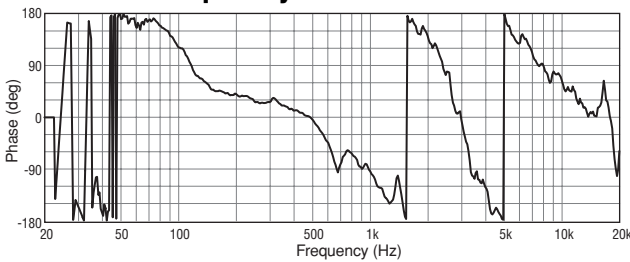

Beamwidth vs. Frequency

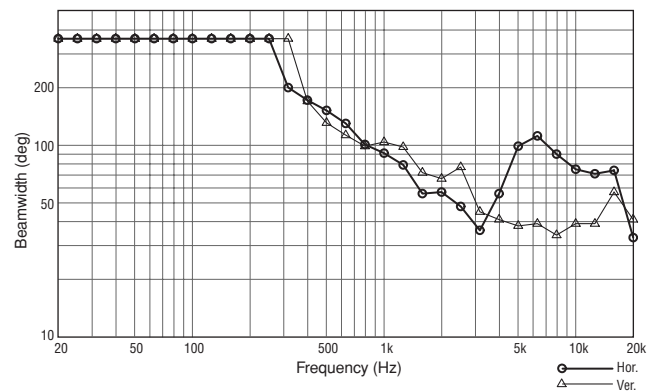

HS-150B/150W

Polar Response (Horizontal)

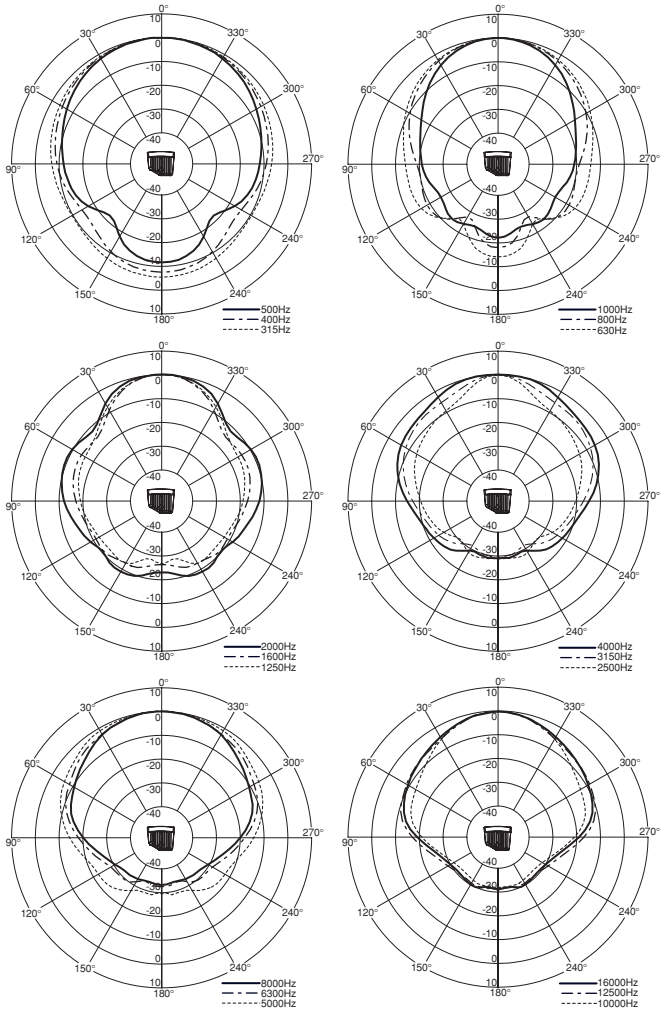

Polar Response (Vertical)

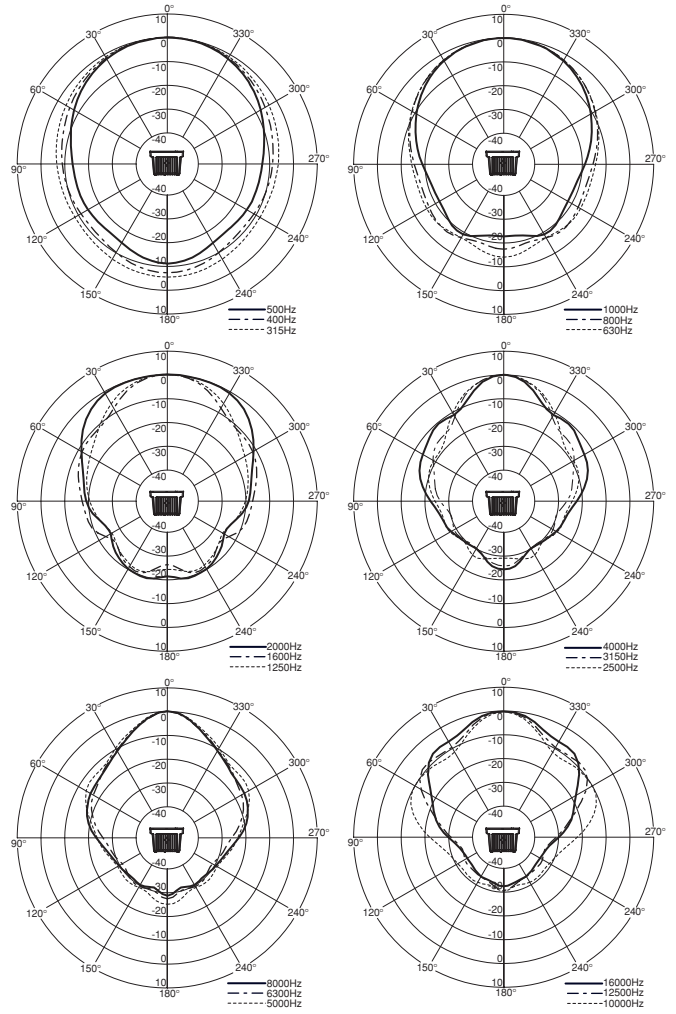

SPL vs. Frequency

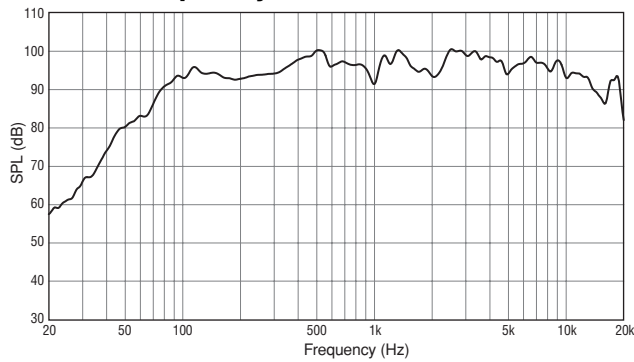

Impedance vs. Frequency

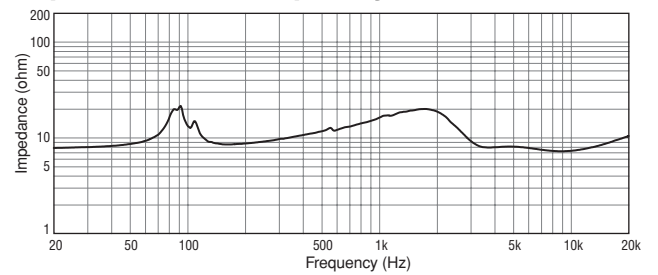

Phase vs. Frequency

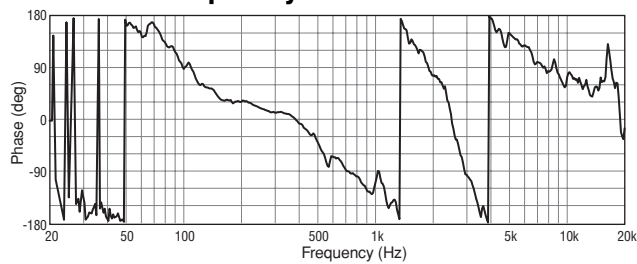

Beamwidth vs. Frequency

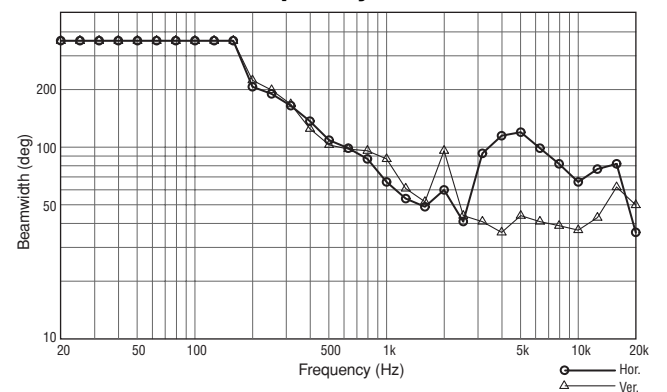

Polar Response (Horizontal)

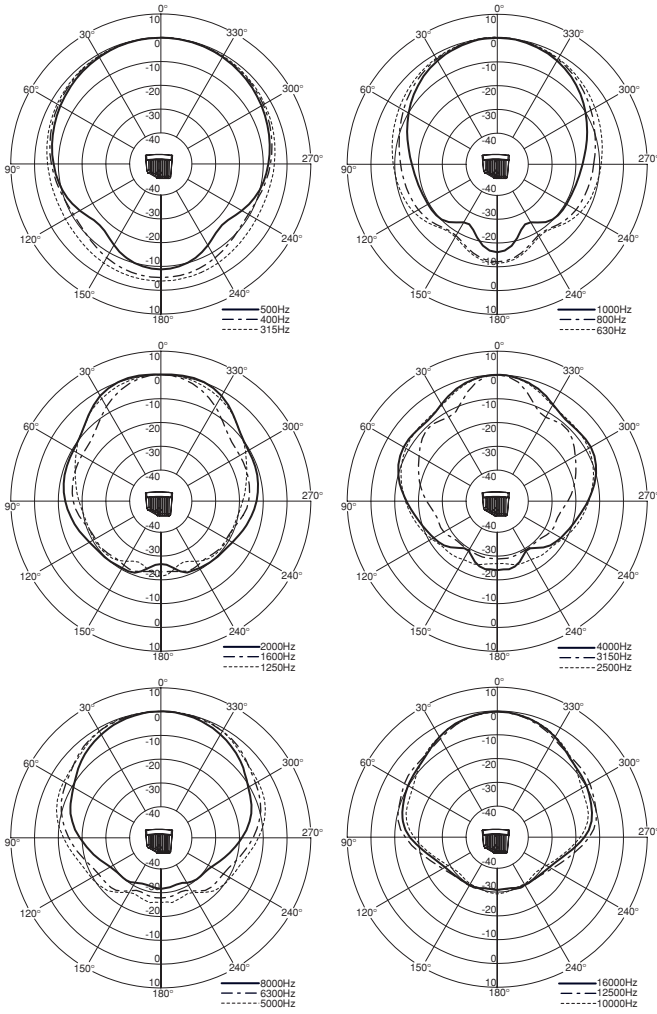

Polar Response (Vertical)

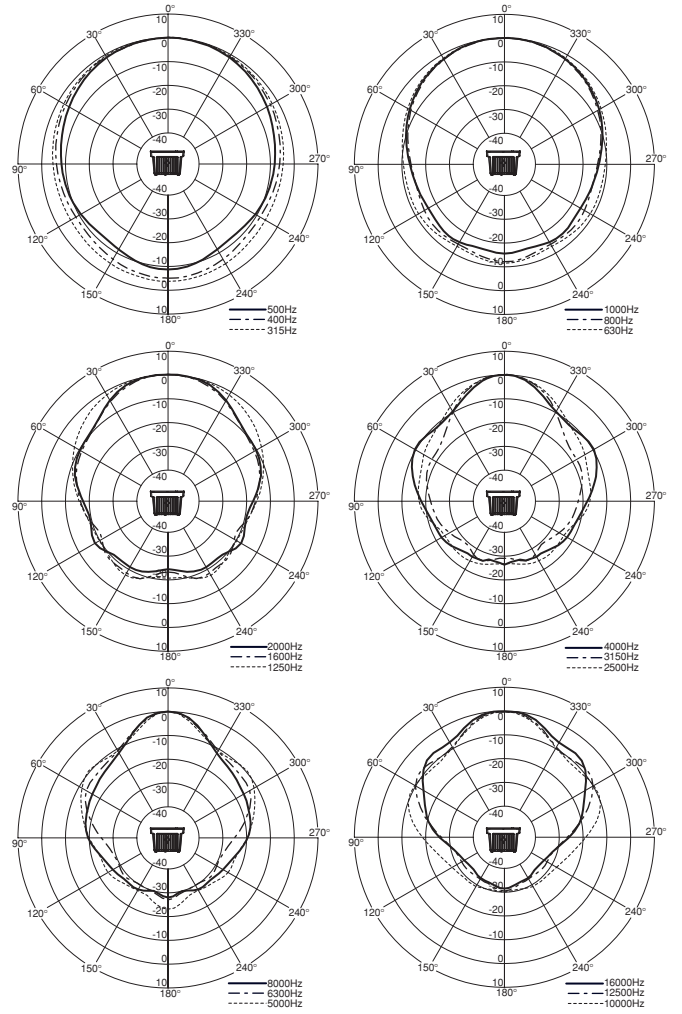

SPL vs. Frequency

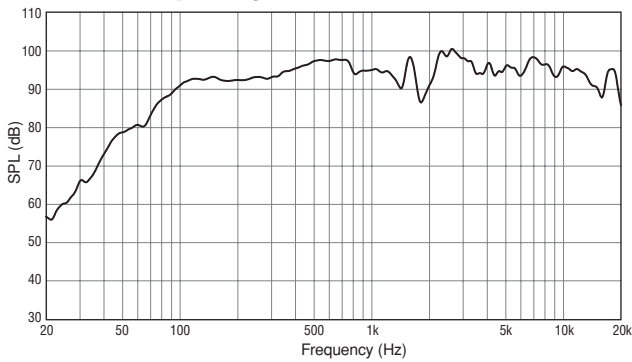

Impedance vs. Frequency

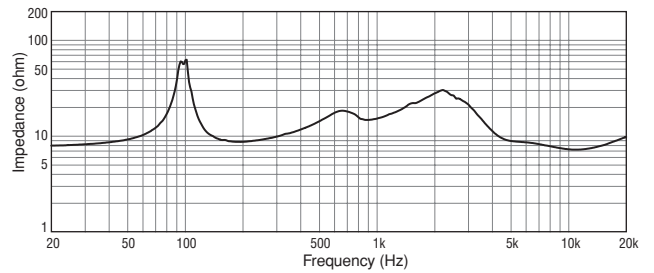

Phase vs. Frequency

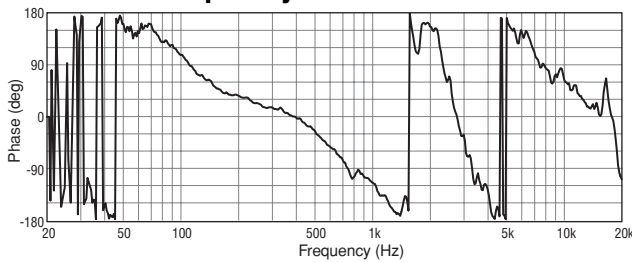

Beamwidth vs. Frequency

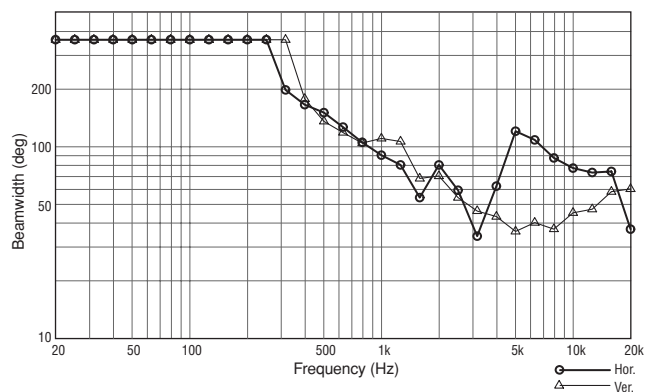

HS-1500BT/1500WT

Polar Response (Horizontal)

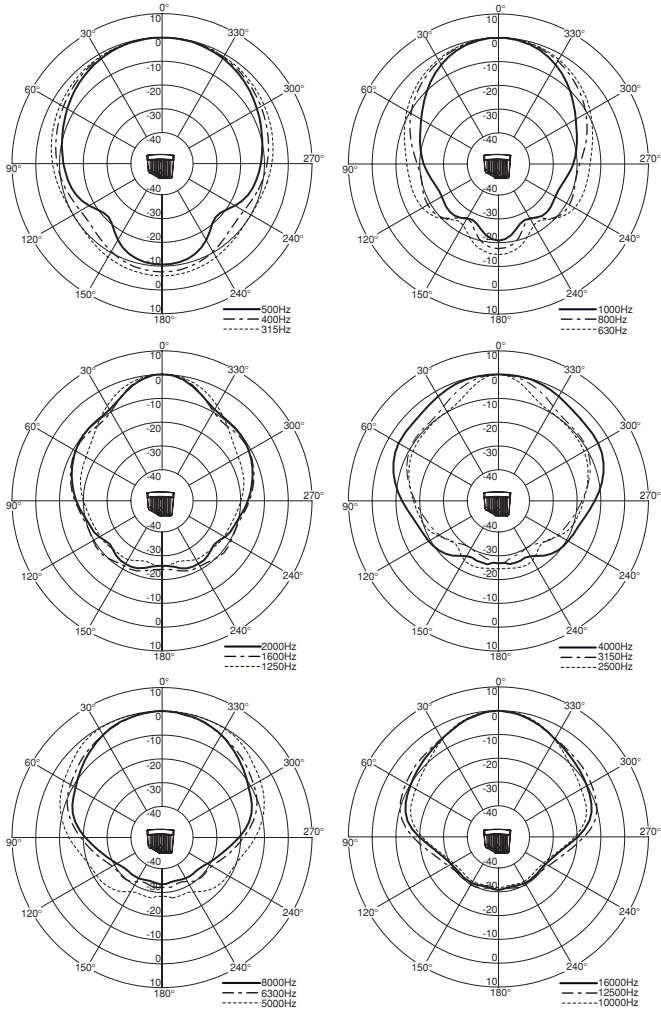

Polar Response (Vertical)

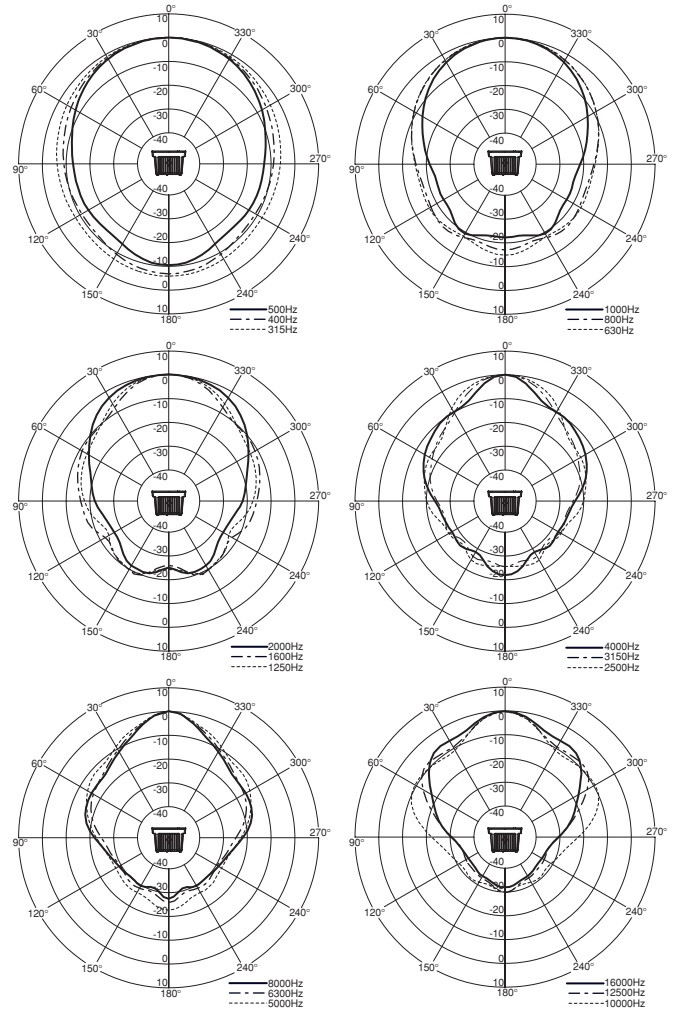

SPL vs. Frequency

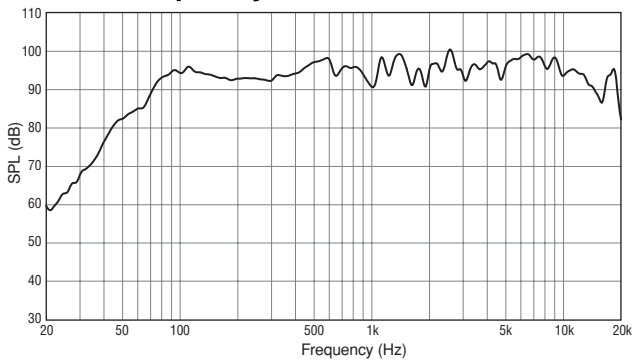

Impedance vs. Frequency

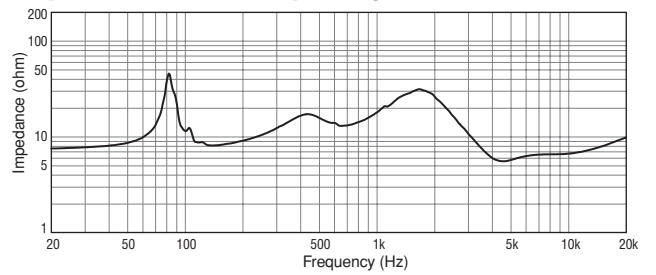

Phase vs. Frequency

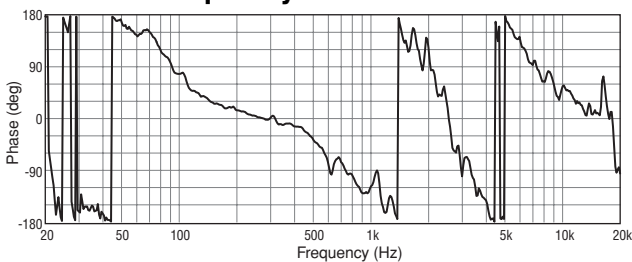

Beamwidth vs. Frequency

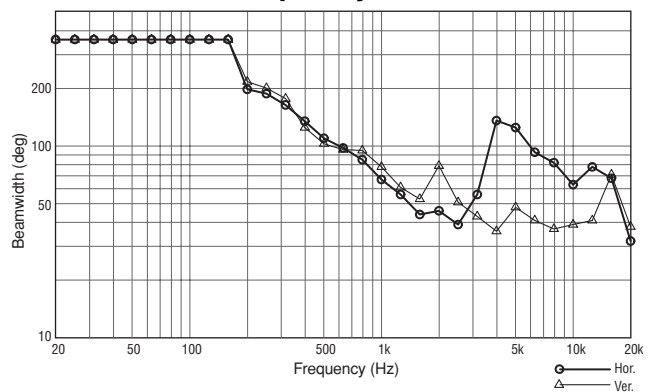

HS-120B/120W/1200BT/1200WT

APPEARANCE AND DIMENSIONAL DIAGRAM

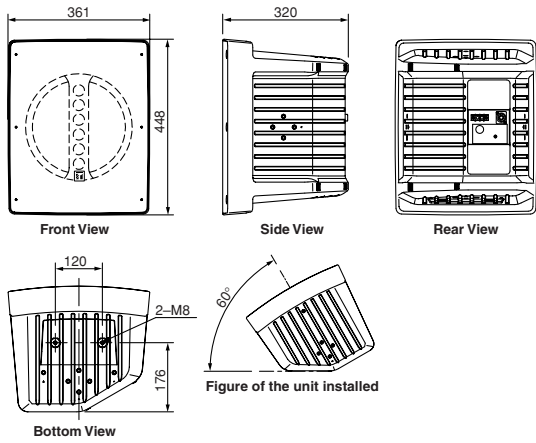

HS-1500B/1500W/1500BT/1500WT

APPEARANCE AND DIMENSIONAL DIAGRAM

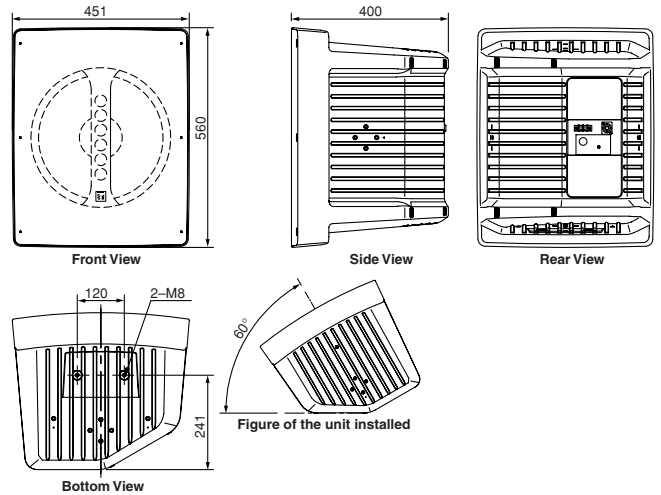

Optional Brackets for HS-120/1200 Series

For wall/ceiling mount

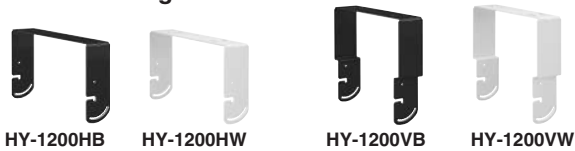

[Ceiling installation]

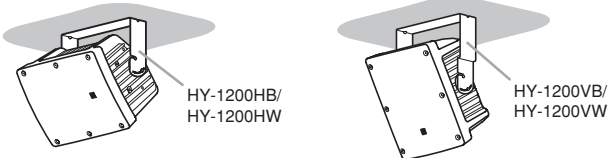

[Wall installation]

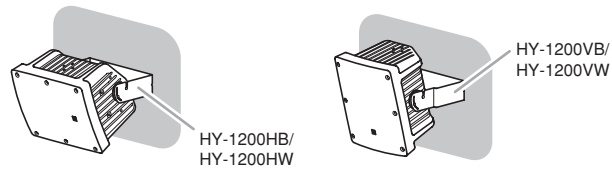

Optional Brackets for HS-150/1500 Series

For wall/ceiling mount

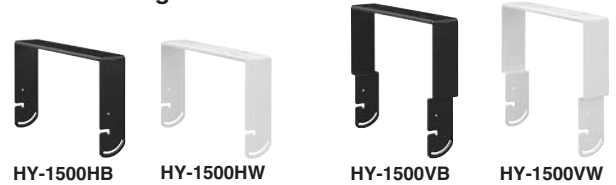

[Ceiling installation]

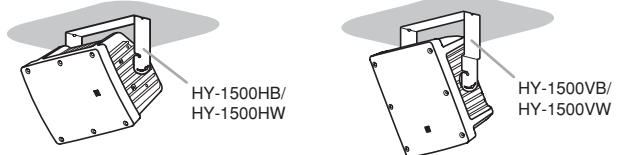

[Wall installation]

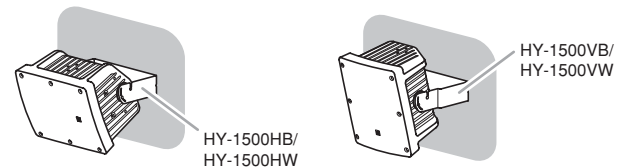

The following brackets allow a speaker's horizontal angle to be adjusted.

For ceiling mount

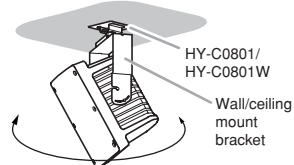

For wall mount

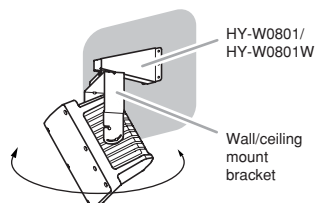
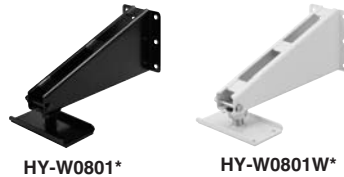

Impedance Change

(HS-1200BT/1200WT/1500BT/1500WT)

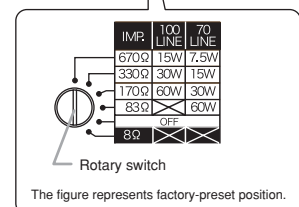
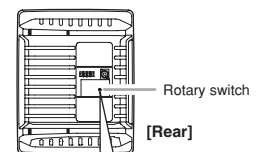

*To be used in conjunction with HY-1200/1500 Series brackets.

ARCHITECTURAL AND ENGINEERING SPECIFICATIONS

HS-120B/120W

The speaker shall be the two-way speaker with a sealed box enclosure with polypropylene and a protective punched front grill with a surface-treated steel plate. The continuous pink noise shall be 100 W at 8 ohms and continuous program power rating of 300 W at 8 ohms. The speaker shall feature a 30 cm (12") woofer and a 6-balanced-dome tweeters array with a 90° × 40° dispersion. Frequency response shall be 80 to 20k Hz, with crossover at 3k Hz. Sensitivity shall be rated at 97 dB (1 W, 1 m). The speaker system shall be designed for both fixed installation uses and on-the-road and shall be capable of being easily carried with an accessory handle. Its built-in overload protection circuitry for tweeter shall cut off a signal when an excessive input signal is received. Input connections shall be via a speakon connector or screw terminal.

The speaker system shall weigh 8.5 kg and shall have dimensions of 361(W) × 448(H) × 320(D) mm. The operating temperature range shall be between -10°C and +50°C. The speakers shall be easily mounted in vertical or horizontal positions, with a wide range of optional brackets.

The two-way speaker system shall be a TOA model HS-120B/HS-120W or approved equivalent.

The wall/ceiling-mount bracket shall be TOA model HY-1200HB/HY-1200HW/HY-1200VB/HY-1200VW.

The ceiling-mount bracket used in conjunction with HY-1200HB/HY-1200HW/HY-1200VB/HY-1200VW shall be TOA model HY-C0801/ HY-C0801W.

The wall-mount bracket used in conjunction with HY-1200HB/HY-1200HW/HY-1200VB/HY-1200VW shall be TOA model HY-W0801/HY-W0801W.

HS-1200BT/1200WT

The speaker shall be the two-way speaker with a sealed box enclosure with polypropylene and a protective punched front grill with a surface-treated steel plate. The speaker shall be compatible with low and high impedance speaker systems and include a built-in 100V matching transformer. The rear panel shall have screwdriver-adjustable tap settings of: 60W, 30W, 15W and 8 ohms. The rated input shall be 60W, the continuous pink noise shall be 100W at 8 ohms and continuous program shall be 300W at 8 ohms. The speaker shall feature a 30 cm (12") woofer and a 6-balanced-dome tweeters array with a 90° × 40° dispersion. Frequency response shall be 70 to 20k Hz, with crossover at 3k Hz. Sensitivity shall be rated at 97 dB (1 W, 1 m). The speaker system shall be designed for both fixed installation uses and on-the-road and shall be capable of being easily carried with an accessory handle. Its built-in overload protection circuitry for tweeter shall cut off a signal when an excessive input signal is received. Input connections shall be via a speakon connector or screw terminal.

The speaker system shall weigh 10 kg and shall have dimensions of 361(W) × 448(H) × 320(D) mm. The operating temperature range shall be between -10°C and +50°C. The speakers shall be easily mounted in vertical or horizontal positions, with a wide range of optional brackets.

The two-way speaker system shall be a TOA model HS-1200BT/HS-1200WT or approved equivalent.

The wall/ceiling-mount bracket shall be TOA model HY-1200HB/HY-1200HW/HY-1200VB/HY-1200VW.

The ceiling-mount bracket used in conjunction with HY-1200HB/HY-1200HW/HY-1200VB/HY-1200VW shall be TOA model HY-C0801/HY-C0801W.

The wall-mount bracket used in conjunction with HY-1200HB/HY-1200HW/HY-1200VB/HY-1200VW shall be TOA model HY-W0801/HY-W0801W.

HS-150B/150W

The speaker shall be the two-way speaker with a sealed box enclosure with polypropylene and a protective punched front grill with a surface-treated steel plate. The continuous pink noise shall be 100 W at 8 ohms and continuous program power rating of 300 W at 8 ohms. The speaker shall feature a 38 cm (15") woofer and a 6-balanced-dome tweeters array with a 90° × 40° dispersion. Frequency response shall be 70 to 20k Hz, with crossover at 3k Hz. Sensitivity shall be rated at 98 dB (1 W, 1 m). The speaker system shall be designed for both fixed installation uses and on-the-road and shall be capable of being easily carried with an accessory handle. Its built-in overload protection circuitry for tweeter shall cut off a signal when an excessive input signal is received. Input connections shall be via a speakon connector or screw terminal.

The speaker system shall weigh 12 kg and shall have dimensions of 451(W) × 560(H) × 400(D) mm. The operating temperature range shall be between -10°C and +50°C. The speakers shall be easily mounted in vertical or horizontal positions, with a wide range of optional brackets.

The two-way speaker system shall be a TOA model HS-150B/HS-150W or approved equivalent.

The wall/ceiling-mount bracket shall be TOA model HY-1500HB/HY-1500HW/HY-1500VB/HY-1500VW.

The ceiling-mount bracket used in conjunction with HY-1500HB/HY-1500HW/HY-1500VB/HY-1500VW shall be TOA model HY-C0801/ HY-C0801W.

The wall-mount bracket used in conjunction with HY-1500HB/HY-1500HW/HY-1500VB/HY-1500VW shall be TOA model HY-W0801/HY-W0801W.

HS-1500BT/1500WT

The speaker shall be the two-way speaker with a sealed box enclosure with polypropylene and a protective punched front grill with a surface-treated steel plate. The speaker shall be compatible with low and high impedance speaker systems and include a built-in 100V matching transformer. The rear panel shall have screwdriver-adjustable tap settings of: 60W, 30W, 15W and 8 ohms. The rated input shall be 60W, the continuous pink noise shall be 100W at 8 ohms and continuous program shall be 300W at 8 ohms. The speaker shall feature a 38 cm (15") woofer and a 6-balanced-dome tweeters array with a 90° × 40° dispersion. Frequency response shall be 60 to 20k Hz, with crossover at 3k Hz. Sensitivity shall be rated at 98 dB (1 W, 1 m). The speaker system shall be designed for both fixed installation uses and on-the-road and shall be capable of being easily carried with an accessory handle. Its built-in overload protection circuitry for tweeter shall cut off a signal when an excessive input signal is received. Input connections shall be via a speakon connector or screw terminal.

The speaker system shall weigh 14 kg and shall have dimensions of 451(W) × 560(H) × 400(D) mm. The operating temperature range shall be between -10°C and +50°C. The speakers shall be easily mounted in vertical or horizontal positions, with a wide range of optional brackets.

The two-way speaker system shall be a TOA model HS-1500BT/HS-1500WT or approved equivalent.

The wall/ceiling-mount bracket shall be TOA model HY-1500HB/HY-1500HW/HY-1500VB/HY-1500VW.

The ceiling-mount bracket used in conjunction with HY-1500HB/HY-1500HW/HY-1500VB/HY-1500VW shall be TOA model HY-C0801/HY-C0801W.

The wall-mount bracket used in conjunction with HY-1500HB/HY-1500HW/HY-1500VB/HY-1500VW shall be TOA model HY-W0801/HY-W0801W.

SPECIFICATIONS

Model No.	HS-120B	HS-120W	HS-1200BT	HS-1200WT
Enclosure	Sealed type			
Rated Input	—		60W (High impedance)	
Power Handling Capacity	Continuous pink noise: 100W, Continuous program: 300W			
Rated Impedance	8Ω		8Ω 100V line: 170Ω (60W), 330Ω (30W), 670Ω (15W) 70V line: 83Ω (60W), 170Ω (30W), 330Ω (15W), 670Ω (7.5W)	
Sensitivity	97dB (1W, 1m)			
Frequency Response	80 – 20,000Hz		70 – 20,000Hz	
Crossover Frequency	3kHz			
Directivity Angle	Horizontal: 90°, Vertical: 40°			
Speaker Component	Low frequency: 30cm (12") cone-type, High frequency: Balanced dome tweeter × 6			
Input Terminal	NEUTRIK NL4MP Speakon and M4 screw terminal, distance between barriers: 9mm			
Operating Temperature	-10°C to +50°C			
Finish	Enclosure: Polypropylene, black Punched net: Surface-treated steel plate, black	Polypropylene, white Surface-treated steel plate, white	Polypropylene, black Surface-treated steel plate, black	Polypropylene, white Surface-treated steel plate, white
Dimensions	361 (W) × 448 (H) × 320 (D)mm			
Weight	8.5 kg		10 kg	
Accessories	Handle × 1, Handle fitting bracket × 2, Handle mounting screw × 2, Rubber foot × 2, Rubber foot mounting screw × 2			
Options	Mounting bracket: HY-1200VB (for vertical speaker mounting) HY-1200HB (for horizontal speaker mounting) Ceiling mount bracket: HY-C0801 Wall mount bracket: HY-W0801 Speaker stand: ST-33B	HY-1200VW (for vertical speaker mounting) HY-1200HW (for horizontal speaker mounting) HY-C0801W HY-W0801W ST-33B	HY-1200VB (for vertical speaker mounting) HY-1200HB (for horizontal speaker mounting) HY-C0801 HY-W0801 ST-33B	HY-1200VW (for vertical speaker mounting) HY-1200HW (for horizontal speaker mounting) HY-C0801W HY-W0801W ST-33B

Model No.	HS-150B	HS-150W	HS-1500BT	HS-1500WT
Enclosure	Sealed type			
Rated Input	—		60W (High impedance)	
Power Handling Capacity	Continuous pink noise: 100W, Continuous program: 300W			
Rated Impedance	8Ω		8Ω 100V line: 170Ω (60W), 330Ω (30W), 670Ω (15W) 70V line: 83Ω (60W), 170Ω (30W), 330Ω (15W), 670Ω (7.5W)	
Sensitivity	98dB (1W, 1m)			
Frequency Response	70 – 20,000Hz		60 – 20,000Hz	
Crossover Frequency	3kHz			
Directivity Angle	Horizontal: 90°, Vertical: 40°			
Speaker Component	Low frequency: 38cm (15") cone-type, High frequency: Balanced dome tweeter × 6			
Input Terminal	NEUTRIK NL4MP Speakon and M4 screw terminal, distance between barriers: 9mm			
Operating Temperature	-10°C to +50°C			
Finish	Enclosure: Polypropylene, black Punched net: Surface-treated steel plate, black	Polypropylene, white Surface-treated steel plate, white	Polypropylene, black Surface-treated steel plate, black	Polypropylene, white Surface-treated steel plate, white
Dimensions	451 (W) × 560 (H) × 400 (D)mm			
Weight	12 kg		14 kg	
Accessories	Handle × 1, Handle fitting bracket × 2, Handle mounting screw × 2, Rubber foot × 2, Rubber foot mounting screw × 2			
Options	Mounting bracket: HY-1500VB (for vertical speaker mounting) HY-1500HB (for horizontal speaker mounting) Ceiling mount bracket: HY-C0801 Wall mount bracket: HY-W0801 Speaker stand: ST-33B	HY-1500VW (for vertical speaker mounting) HY-1500HW (for horizontal speaker mounting) HY-C0801W HY-W0801W ST-33B	HY-1500VB (for vertical speaker mounting) HY-1500HB (for horizontal speaker mounting) HY-C0801 HY-W0801 ST-33B	HY-1500VW (for vertical speaker mounting) HY-1500HW (for horizontal speaker mounting) HY-C0801W HY-W0801W ST-33B



TOA Corporation

www.toa.jp

Specifications are subject to change without notice.
Printed in Japan (0803) 833-61-655-30 U